

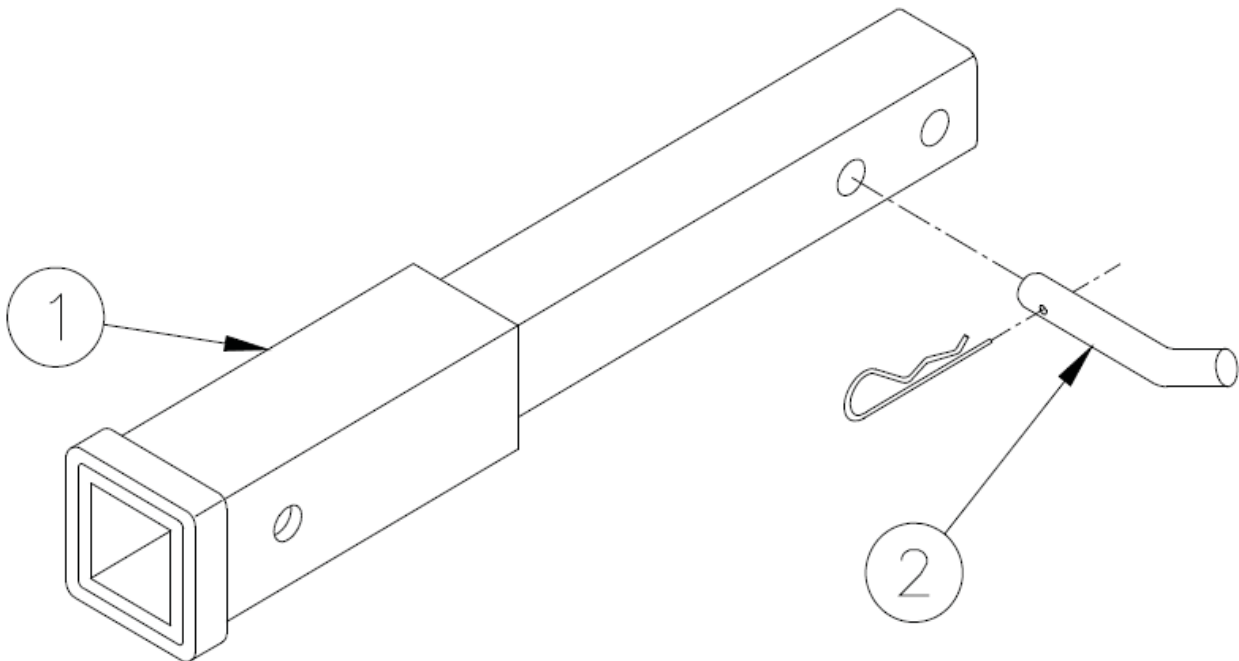

**Installation Instructions  
Receiver Extension, Class IV\*  
BX88160**

- Slide the receiver extension into the receiver hitch and pin it in place with the 5/8" pin and clip provided.  
\*Maximum weight distributing of 250 lbs at tongue, with 10,000 lbs towing capacity.



**Parts List**

Ref. No.	Qty.	Part No.	Description
1	1	61-5551	Weldment, Receiver Extension, BX88160
2	1	200-1483	Pin, 5/8 X 3 Eff. w/ clip

**Automatic**